



# APE Plastic Piling

Tel 01543 277680-Fax 01543 270090- info@miniape.com  
www.miniape.com

## ProLock Plastic Pile Specifications as of 2/9/2008



Pile		ProLock	Softwood C1 Post	Steel Tube		
Quantity per metre wall		2	2	2	2	2
Allowable Bending Moment (M)	kNm/m	<b>7.09</b>	<b>6.96</b>	<b>24</b>	<b>35.7</b>	<b>58</b>
Section Modulus (Z)	cm <sup>3</sup> /m	315	663	102		
Moment of Inertia (I)	cm <sup>4</sup> /m	3950	4970	713		
Stiffness EI	kNm <sup>2</sup> /m	91	447	1498		
Flexural Strength f <sub>m, kar</sub>	Mpa	60				
Design Flexural Strength f <sub>u, d</sub>	Mpa	22.50				
Modulus of Elasticity (E) Serviceability Limit State	Mpa	2300	9000	2.1 E+11		
Effective Pile Width	mm	500				
Depth/Diameter of Section	mm	175	150	139.7		
Thickness (if Section or Tube)	mm	6		3.6	5.6	10.0
Material		PVC	C1	Steel FeE235		
Weight per m (product)	Kg	8.4				

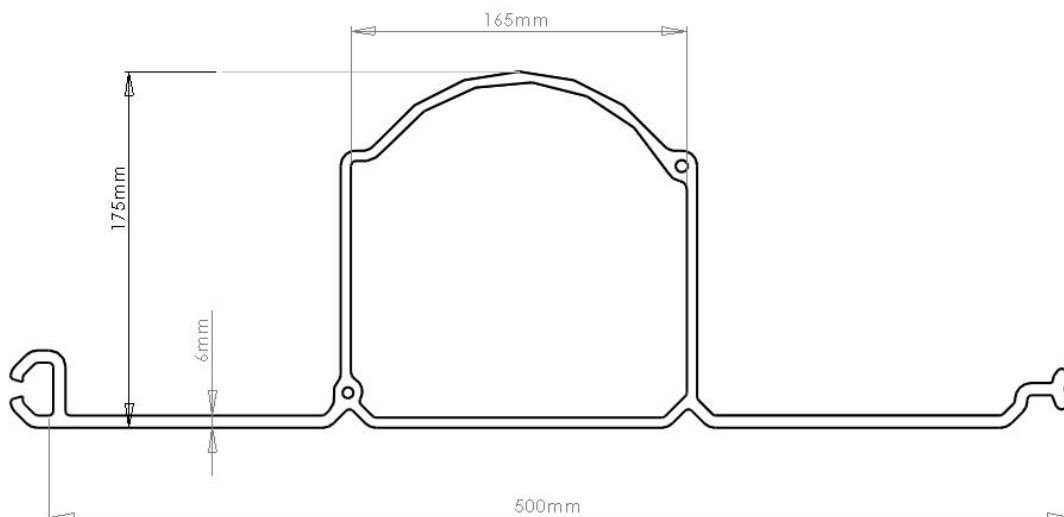

# Bending Moments and Hybrid

ProLock alone has a bending moment of 7 kNm/m, the manufacturers and their design engineers Geoconsult Noord, have based the product concept on an additive method, when used as a hybrid system with timber or steel; where both pile and post or tube are present. Note in a king panel design, there are clearly regions of the wall which are solely the tube or post.

With two hexagonal tubes built into its design, either or both of these can be used, so long as the space between post/tube does not exceed 50cm. See below for examples

Pile Options	ProLock	ProLock plus 1x 150 C1 timber post	ProLock plus 1 139.7mm OD 3mm Steel Tube	ProLock plus 1 x 139 mm x 5-6mm Steel Tube
Bending Moment	7	7 + 7	7 + 24	7+ 35
Total Bending Moment	7	14	31	42

Independent Analysis by the Caparo Innovation Centre, commissioned by APE, has stated where a design needs to be considered as conservatively as possible, the bending moments of hybrids should be based upon the stiffer of the two elements alone, as this will be supporting the loads, rather than a distribution between pile and post. In this more conservative approach the bending moment is based on a single element and so hybrid benefits are not taken into account.

